

## Load Frequency Control of A Typical Two Area Interconnected Power System by Using Battery Energy Storage System

K. Rajasekhar Chowdary<sup>1</sup>, P. Santhoshi<sup>2</sup>, S. Bhaskararao<sup>3</sup>, T. Anusha<sup>4</sup>, S. Vasu Devarao<sup>5</sup>.

<sup>1</sup>(Asst. professor Department of Electrical and Electronics Engineering, Lendi Institute of Engineering and Technology, Jonnada, Vizianagaram-535005)

<sup>2,3,4,5</sup> (U.G Student Department of Electrical and Electronics Engineering, Lendi Institute of Engineering and Technology, Jonnada, Vizianagaram-535005, JNTUK).

### Abstract

The main objective of this paper is to maintain the constant frequency in two area interconnected power system by using Battery Energy Storage System (BESS) . When there is a variation in the load demand on a generating unit, there is a momentary occurrence of unbalance between real power input and output. LFC helps in maintaining the scheduled system frequency and tie-line power interchange with the other areas within the prescribed limits .To control the load frequency and compensate the power imbalance the conventional controllers are used in olden days. But ,these conventional controllers are slow and donot allow the controller designer to take into account possible changes in operating condition and non-linearities in the generator unit.The advancement technique to control the load frequency, an external Battery Energy Storage (BES) system is incorporated. Frequency oscillations due to large load disturbance can be effectively damped by fast acting energy storage devices such as Battery Energy Storage systems.This paper presents the qualitative and quantitative comparison of conventional controllers and BES system in Load Frequency Control (LFC) of a typical two area interconnected power system. The performance of BESS over conventional controllers and how the disturbances are controlled and maintain the constant frequency with response are highlighted.

**Keywords**-powersystem; load frequencycontrol; conventional controllers; battery energy storage system.

### I. INTRODUCTION

Power systems are used to convert natural energy into electric power .They transport electricity to factories and houses to satisfy all kinds of power needs .To optimize the performance of electrical equipment, it is important to ensure the quality of the electric power.The active & reactive power balance need to be continuously maintained,as they correspond to two equilibrium points: frequency and voltage respectively. A good quality of the electric power system requires both the frequency and voltage to remain at standard values during real time operation of electric power networks.As a result of the power imbalance, the frequency and voltage levels will be varying with the dynamic load perturbations. This necessitates the need for effective controller logic to cancel the effects of the random load perturbations and to keep the frequency and voltage at the standard values. Although the active power and reactive power have combined effects on the frequency and voltage, the control problem of the frequency and voltage can be decoupled. The frequency is highly dependent on the active power, while the voltage is highly dependent on the reactive power. Thus the control issue in power systems can be decoupled into two independent problems. The

active power and frequency control is referred to as load frequency control (LFC). The reactive power and voltage control is referred to the automatic voltage regulation (AVR) [1]. The foremost task of LFC is to keep the frequency constant against the randomly varying active power loads and also to regulate the tie-line power exchange error.

The power system Load Frequency Control (LFC) problems are caused by small load perturbations which continuously disturb the normal operation of power systems.

Therefore, the generation rate must be changed until the frequency and tie-line power are maintained close to their acceptable limits.The output power of generator is controlled with mechanical input. LFC problem is very important in interconnected power system because the load perturbation in any area will disturb the frequency of other areas. When there is a variation in the load demand on a generating unit there is a momentary occurrence of unbalance between real power input and output. This difference is being supplied by the stored energy of rotating parts. When the kinetic energy decreases, the speed decreases, hence there is a frequency deviation. This change in frequency is being sensed by speed governor system and the input

to the prime mover is adjusted in such a way that change in frequency is nullified.

In recent years, literatures have reported the use of different controller designs for load frequency control. Lim et al [2] has proposed a robust decentralized load frequency controller based on Riccati-Equation approach for multi-area power systems with parametric constraints. Conventional PID controller has been widely used for load frequency control Expert systems like fuzzy logic, neural network [3],[4], [5] have been later applied to overcome the pitfalls of conventional controller. The application of BES for LFC evolved in the year 2001. Aditya et al [6] have applied BES for load frequency control of an interconnected reheat thermal system Recently, Kalyan Chatterjee [7] has studied the effect of Battery Energy Storage System on LFC in deregulation environment.

In this paper, a different scheme of controller design is applied, where in the conventional controller is replaced by external battery energy storage system. The performance of BESS is tested by carrying out detailed simulation study on a typical two area interconnected power system.

## II. TWOAREASYSTEM

In two-area system, two single area systems are Inter- connected via the tie line. Inter-connection is established in order to increase the overall system reliability [1]. Even if some generating units in one area fail, the generating units in the other area can compensate to meet the load demand. The schematic block diagram of two area inter connected system is shown in Fig .1

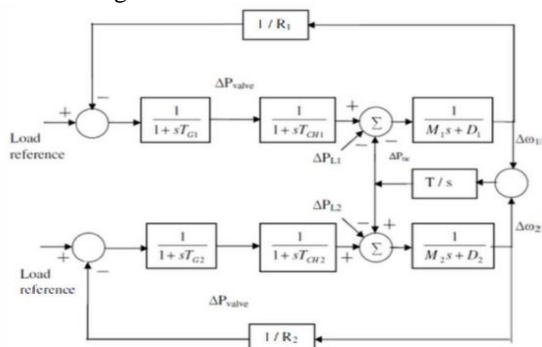

Fig. 1. Block Diagram of Interconnected Two Area System

## III. CONVENTIONAL CONTROLLER

In order to keep the power system in normal operating state, a number of controllers are used in practice. As the demand deviates from its normal operating value the system state changes. Different types of controllers based on classical linear control theory have been developed in the past.

### A. Integral Controller

Integral controller works such that the signal driving the controlled system is derived by integrating the error in the system. The transfer function of the controller is  $K_i/s$ , where  $K_i$  is the integral constant. We can design a stable integral control system; the steady state error (SSE) will become zero [3]. The block diagram of LFC in single area system using integral controller is shown in Figure.2. The frequency response of the controller when simulated for the single area system is shown in Fig. 3. The simulation result identifies that the system starts oscillating widely and steady state cannot be acquired. Hence integral controller is infeasible for practical implementation.

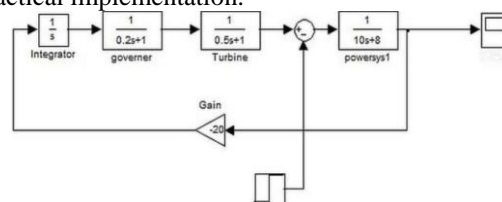

Fig. 2. LFC of single area system using integral controller

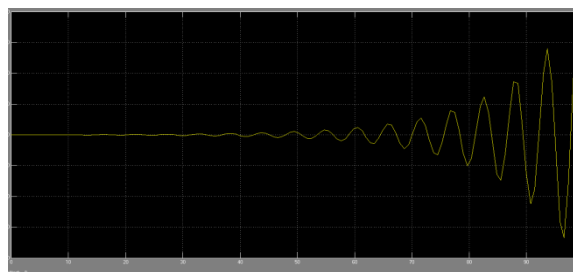

Fig. 3. Response of single area LFC using integral controller

### B. PID Controller

PID controller involves three separate constant parameters, and is accordingly sometimes called three-term control the proportional, the integral and derivative values, denoted P, I, and D. Heuristically, these values can be interpreted in terms of time: P depends on the present error, I on the accumulation of past errors, and D is a prediction of future errors, based on current rate of change. The weighted sum of these three actions is used to adjust the process via a control element  $r_{51}$ . A typical mathematical model of an interconnected two area system is depicted in Fig. 1.

The two area system incorporating LFC by the use of PID controller build with test parameters taken from [3] is shown in Fig.4. PID controller effectively controls the change in frequency with accordance to the change in load. The response of the LFC of two area system using PID control is depicted in Fig. 5, with the response plot of Area1 highlighted

in pink color and that of Area 2 highlighted in yellow color. It is observed from Fig. 5 that when there is a change in the load the frequency deviates and takes up an overshoot, but the PID control is seen to effectively damp the oscillation and make the system to get settled as fast as possible.

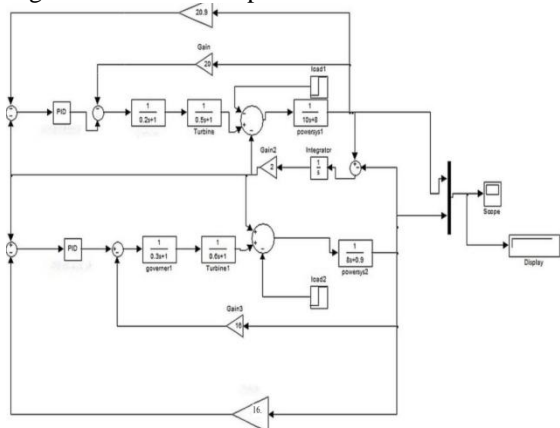

Fig. 4. LFC of Two Area System using PID Controller

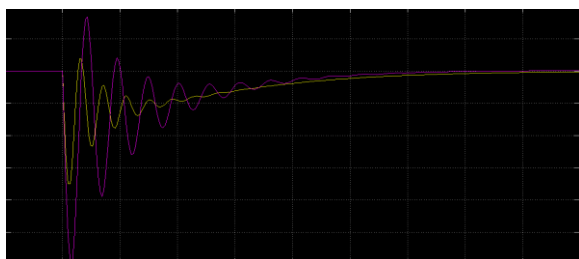

Fig.5. Frequency Response of LFC of two area controller using PID controller.

#### IV. BATTERY ENERGY STORAGE SYSTEM

Secondary control or load frequency control is one of the most important control functions in the operation of inter-connected power systems, regulating the frequency and tie-line interchanges among different control areas. Currently, in many countries, the electric power industry is in transition from vertically integrated utilities, providing power at regulated rates, to an industry that will incorporate competitive companies selling unbundled power at lower rates. In the power system structure, load frequency control acquires a fundamental role to enable power exchanges and to provide better conditions for electricity trading. One alternative to improve the performance of LFC is the introduction of storage facilities during peak load period and specially a battery energy storage facility. Since BESS can provide fast and active power compensation, it can also be used to improve the performance of load frequency control.

BES also improves the reliability of supply during peak load period. Storage facilities possess additional dynamic benefits such as load leveling, factor correction and black start capability [7].

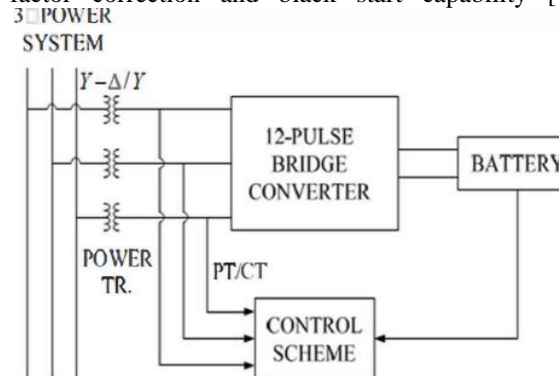

Fig.6. Schematic description of BES plant

#### A. Block Diagram of BES Model

A schematic description of a BES plant is given in Fig.6. The main components of the BES facility are, an equivalent battery composed of parallel /series connected battery cells, a 12-pulse cascaded bridge circuit connected to a Y/Y transformer and a control scheme[6].

#### B. Incremental Model of BES

The equivalent circuit of the BES can be represented as a converter connected to an equivalent battery as shown in Fig 7. In the battery equivalent circuit,  $E_{boc}$  is battery open circuit voltage,  $E_b$  is battery overvoltage,  $r_{bt}$ , connecting resistance, and  $r_{bs}$  stands for internal resistance. The ideal no load maximum d.c. voltage of the 12-pulse converter is expressed as  $E_{do}$ , as given in Eqn. (1)

$$E_{do} = E_{do1} + E_{do2} = \frac{6\sqrt{6}}{\pi} E_t \quad (1)$$

where  $E_t$  is the line to neutral r.m.s voltage. The expression of d.c. current flowing into the battery is given by Eqn. (2).

$$I_{bes} = \frac{(E_{bes} - E_{boc} - E_b)}{(r_{bs} + r_{bt})} \quad (2)$$

According to the converter circuit analysis active and reactive power absorbed by the BES system are given by  $P_{bes}$  and  $Q_{bes}$  given by Eqns. (3) and (4) respectively.

$$P_{bes} = \frac{3\sqrt{6}}{\pi} E_t I_{bes} (\cos \alpha_1^0 + \cos \alpha_2^0) \quad (3)$$

$$Q_{bes} = \frac{3\sqrt{6}}{\pi} E_t I_{bes} (\sin \alpha_1^0 + \sin \alpha_2^0) \quad (4)$$

where  $\alpha_1^0$  and  $\alpha_2^0$  are the firing delay angle of converter 1 and converter 2 used in BES model.

The integral control law is described by Eqn. (5) as

$$U_i(t) = -KI_i \int ACE_i(t)dt \quad (5)$$

where,  $KI_i$  is the integral gain setting of area  $i$  ACE of area  $i$

in terms of  $B$ ; the frequency bias setting of area  $i$ .

$$ACE_i = B_i \Delta f_i + \Delta P_{tie} \quad (6)$$

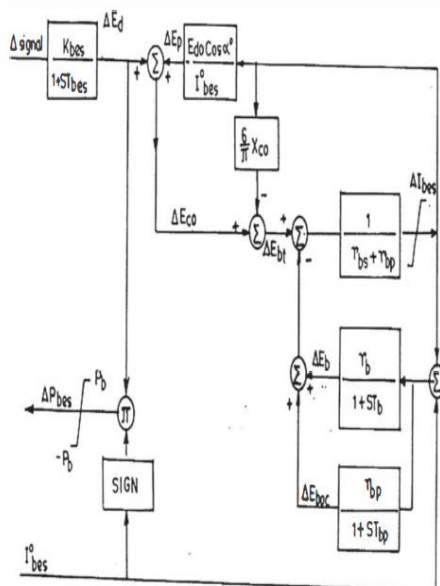

Fig.7. Incremental model of BES

## V. RESULTS AND DISCUSSION

The BES model discussed in the previous section has been implemented in a sample two area inter-connected power system Initially, the BES model is designed in MATLAB B/ Simulink Environment as a subsystem and then later implemented in the main Simulink model. The parameters used in the design of BES model are shown in the Appendix. The battery energy storage system with the given specifications is simulated for an interconnected power system using MATLAB simulation studies. Initially the incremental model of BES is being simulated and it is incorporated along with a single area system and an interconnected two area power system Fig 8 and Fig 10 shows the Simulink model of BES for single area LFC and two area LFC respectively. The Fig 9 and Fig 11 show the frequency response plot of the LFC for single area and two area systems respectively. Fig.

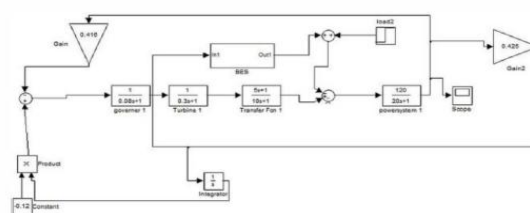

Fig. 8. Simulink model of BES incorporated to single area LFC

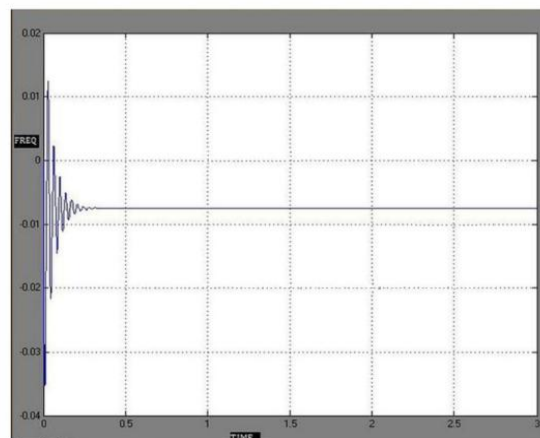

Fig.9. Response of BES for single area system LFC.

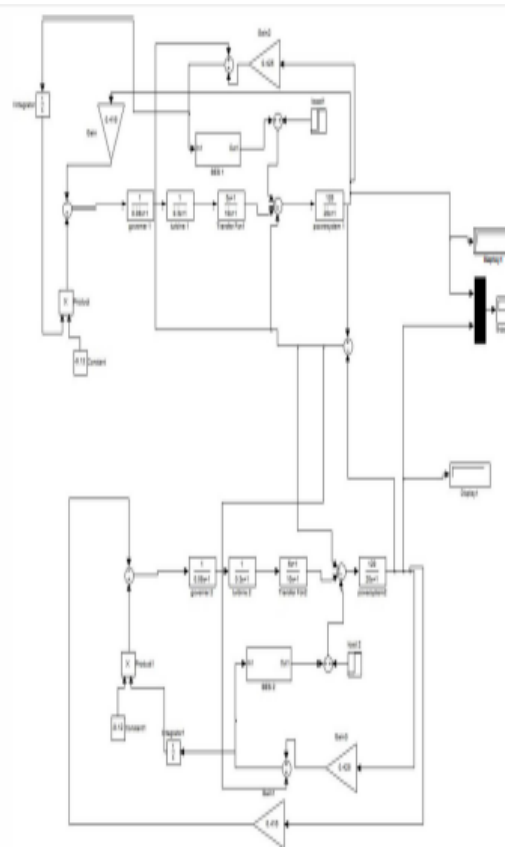

Fig. 10. Simulink model of BES for two area system LFC

It is inferred from the response curves of the simulation studies of BESS (Fig. 9 and Fig. 11) that the load frequency oscillations settles around 0.5 to 0.8 seconds for both single area system and two area system. This is seen to be a comparably good performance when compared with the conventional controllers which had an average of 12 seconds of settling time and ANN controller which had around 9 seconds of average settling time, The BES system is thus is proven to be highly efficient and the settling time decreases to about 10 times of the other controllers. Hence these external storage devices such as BES incorporation to the power system helps in improving the dynamic response of the system even for step loads and maintain a good Load Frequency Control of the system.

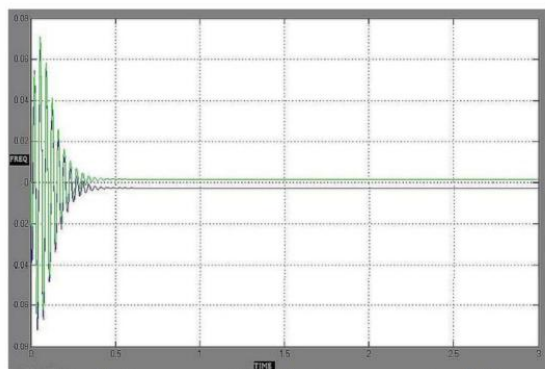

Fig.11. Response of BES for two area system LFC

## VI. CONCLUSIONS

This work has presented the application of BES in load Frequency control of interconnected power systems. It has been identified through simulation study that BES very well replaces PID controller and has proven to give a better performance compared to conventional controllers. Comparison of performance responses shows that BES has quite satisfactory generalization capability, feasibility and reliability, as well as accuracy in Load Frequency Control of interconnected power systems. Future work will focus on the implementation of hybrid model combining both BES system and ANN or Conventional Controllers to achieve a further better performance in Load Frequency Control of power systems.

## VII. APPENDIX

### Data for power system:

$f=60\text{hz}$   
 $P_{r1}=P_{r2}=1000\text{MW}$   
 $K_{p1}=K_{p2}=120\text{HZ/pu MW}$   
 $T_{p1}=T_{p2}=20.0\text{s}$   
 $K_{r1}=K_{r2}=0.5$   
 $T_{r1}=T_{r2}=10.0\text{s}$   
 $T_{g1}=T_{g2}=0.08\text{s}$   
 $T_{t1}=T_{t2}=0.3\text{s}$

$R_1=R_2=2.4\text{ HZ/ pu MW}$   
 $B_1=B_2=0.425\text{ pu MW/HZ}$

### BES (10 MW/40 MW b):

Battery voltage=1755-2925 V d.c.  
 $C_{pb}=52597\text{ F}$   
 $R_{pb}=10\text{K}\Omega$   
 $C_b=1\text{ F}, R_b=0.001\Omega$   
 $R_{bt}=0.0167\Omega$   
 $R_{bs}=0.013$   
 $X_{c0}=0.0274\Omega$   
 $I_{bes}=4.426\text{ KA}$   
 $K_{bes}=100\text{ KV/pu MW}$   
 $T_{bes}=0.026\text{ s}$   
 $\alpha=15^\circ, \beta=25^\circ$

## REFERENCES

- [1] Haadi Saadat, Power Sy&em Analysis, PSA publishing, 2010.
- [2] Sundaram, VS. and Jayabarathi, T, "Load Frequency Control using PID tuned ANN controller in po□r sy&em," Proc. International Conference on Electriml Energy Systems (iC EES), 2011, pp. 2 69-274, Jan. 2011.
- [3] Rengarajan,N., Ra vichandran, C.S. and Palani, S, "Artificial Neural Net\\QIK based design of governor controller," Amdemic Open internet Journal, Vol. 20, 2007 .
- [4] Kalyan Chatterjee, "Effect of Battery Energy S:orage Sy&em on Load Frequency Control under Deregulation," international Journal of Emerging El ectric Power System s, Vol. 12 , issue 3,Article 2, June 2011.
- [5] MATLAB SIMULINK ® - Simulation and Model Based Design, <http://www.math\\Q rks.com>.
- [6] KimbaIk, EW, Direct Current Tran:mission, Vol. 1, Wiley, New YoIk, 1971.
- [7] Lim, K. Y, Wang, Y and Zhou, R, "Robust decentrali9.::d loadfrequency control of multi- area po□r >y&ems," iEE Generation, Trammission and Distribution, Vol. 143, issue 5, pp. 377-386, Sep. 1996.
- [8] Umrao, R. and Chattrved□ D.K, "Load frequency control using polar fuzzy controller," Proc. TENCON 2010 iEEE Region 10 Confonence, pp. 557-562, Nov. 2010 .
- [9] Aditya,S.K. and Das, D, " Battery energy &orage for load frequency control of an interconnected po□r sy&em," Electric Power Systems Research, Vol. 58, issue 3, pp. 179-185, July 2001.
- [10] Rerkpreedapong, D., Atic, N. and Feliachi, "Eco nomy oriented mod el predictive load frequency controV' Proc. Large Engineering

Systems Conference on Power Engineering, pp. 12-16, May 2003.

- [11] Salameh, ZM., Casacca, M.A. and Lynch, W.A, "A mathematical model for lead-acid batteries," IEEE Transactions on Energy Conversions, Vol. 7, issue 1, pp. 93-98, March 1992 .
- [12] H.J. Kunsch, K.G. Kramer and H Dominik, "Battery Energy Storage Another option for load-frequency-control and instantaneous reserve," IEEE Transactions on Energy Conversions, Vol. 1, issue 3, pp. 41-46, Sep.1996